

NO	QTY	DESCRIPTION	MODEL NUMBER			STANDARD SEAL KIT
			L1-4132-00-X-US	L1-4140-00-X-US	L1-4150-00-X-US	
1	1	NUT, JAM, HEX	21-5100-01	21-5100-02	21-5100-03	
2	3	SPRING, COMPRESSION	23-3500-85	23-3500-86	23-3500-86	X
3	3	BALL, TUNGSTEN-CARBIDE	23-6500-09	23-6500-10	23-6500-10	X
4	2	O-RING, PLUG SEAL	39-0510-79	39-0510-79	39-0510-80	X
5	1	O-RING, CAP SEAL	39-0510-82	39-0510-83	39-0510-84	X
6	2	O-RING, MANIFOLD SEAL	39-0510-87	39-0510-87	39-0510-88	X
7	1	SEAL, WIPER, SNAP IN	39-0530-42	39-0530-43	39-0530-45	X
8	1	SEAL, STEP, ROD	39-0560-02	39-0560-03	39-0560-05	X
9	1	SEAL, CAP, PISTON	39-0560-22	39-0560-23	39-0560-24	X
10	2	PLUG, SOCH	43-0680-04	43-0680-04	43-0680-06	
11	1	PLUNGER, LEFT HAND (SHOWN)	81-4001-32	81-4001-33	81-4001-34	
	1	PLUNGER, RIGHT HAND	81-4001-42	81-4001-43	81-4001-44	
	1	PLUNGER, STRAIGHT	81-4001-22	81-4001-23	81-4001-24	
12	1	CAP, LC/SC, 7MP α	81-4001-52	81-4001-53	81-4001-54	
13	2	PLUG, MANIFOLD, 7MP α	81-4002-00	81-4002-00	81-4002-01	
14	3	PIN, STOP ,BALL, METRIC	81-4002-02	81-4002-03	81-4002-03	X
15	1	SENSOR, ULTRASONIC, M12, 1m	29-7402-00	29-7402-00	29-7402-00	
16	1	SENSOR, FACE SEAL	43-0000-40	43-0000-40	43-0000-40	
N/A	N/A	SEAL KIT (STANDARD)	L6-0143-20	L6-0144-00	L6-0145-00	NOTED

B

B

A

A

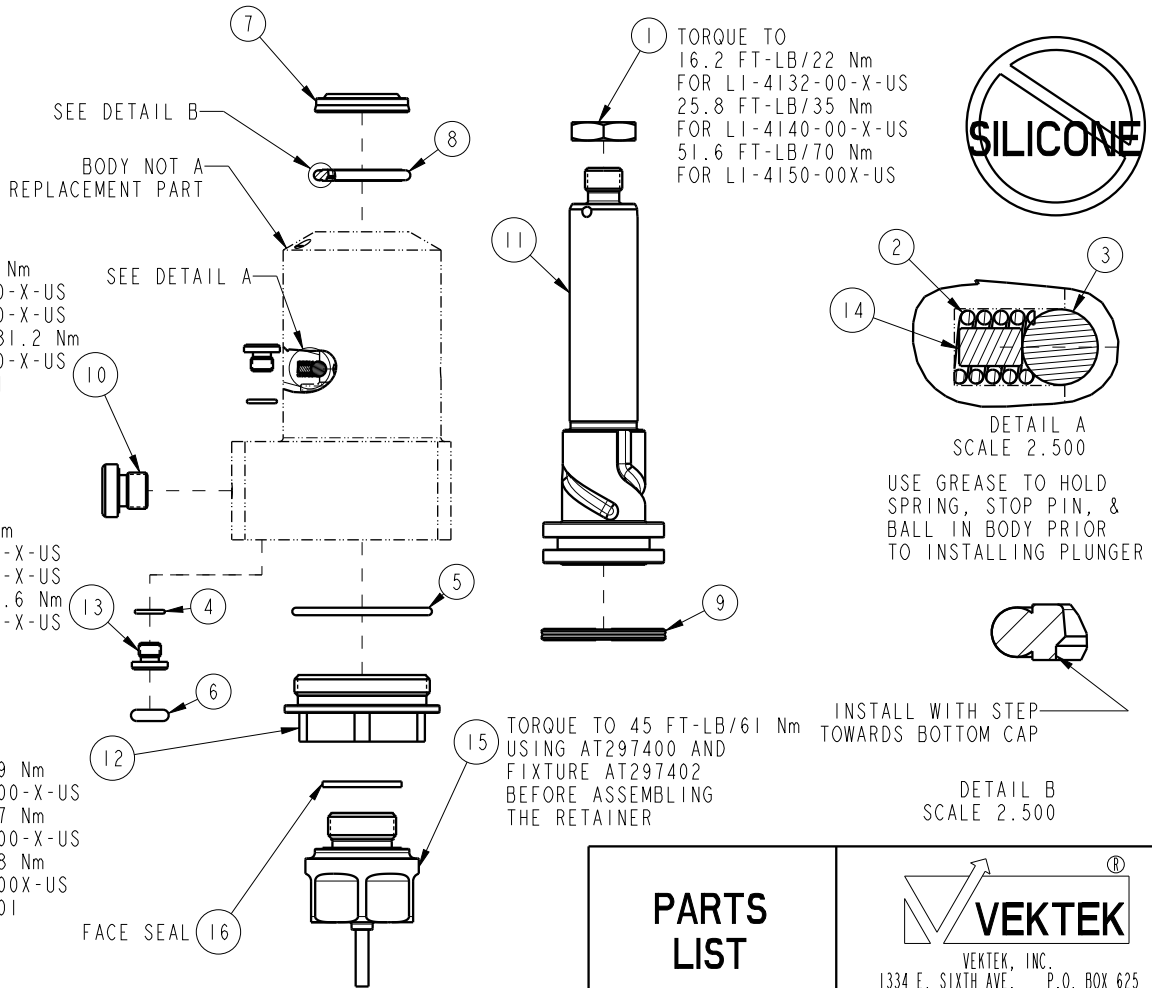

PARTS LIST		
	VEKTEK, INC. 1334 E. SIXTH AVE. P.O. BOX 625 EMPORIA, KS. 66801 U.S.A.	
ASSEMBLIES AFFECTED	PARTS LIST, ASSY, SC, BF, 7MP α , 32B, 40B, 50B	
L1413200XUS L1414000XUS L1415000XUS	SIZE A	LPL1464
		REV A

A	5779	RELEASE	ALS	7/29/25
REV	IN ACCORDANCE WITH ECN	EFFECTIVE DATE	REVISED BY	DATE
DRW BY: ALS	DRAWING STATUS: Released			
DATE: 7/28/25	PRODUCTION APPROVED FOR RELEASED STATUS ONLY			

1

2

FORM FEG035_PL_ASIZE, REV. B

SHEET 1 OF 1